

ITEM NO.	PART NUMBER	DESCRIPTION	QTY.
1	NMFP 01_02	BASE PLATE	1
2	NMFP 01_03	BEARING BLOCK	4
3	NMFP 01_04LH	LH TOOTH	1
4	NMFP 01_05	RAMP PLATE	1
5	NMFP 01_04RH	RH TOOTH	1
6	ISO 10642 - M12 x 35 - -- 35N	M12 Countersunk Screw	8
7	ISO 7040-M12-N	M12 Nyloc Nut	8
8	ISO 8765 - M12x1.5 x 50 x 30-N	M12 Bolt	4

SECTION A-A  
SCALE 1 : 5

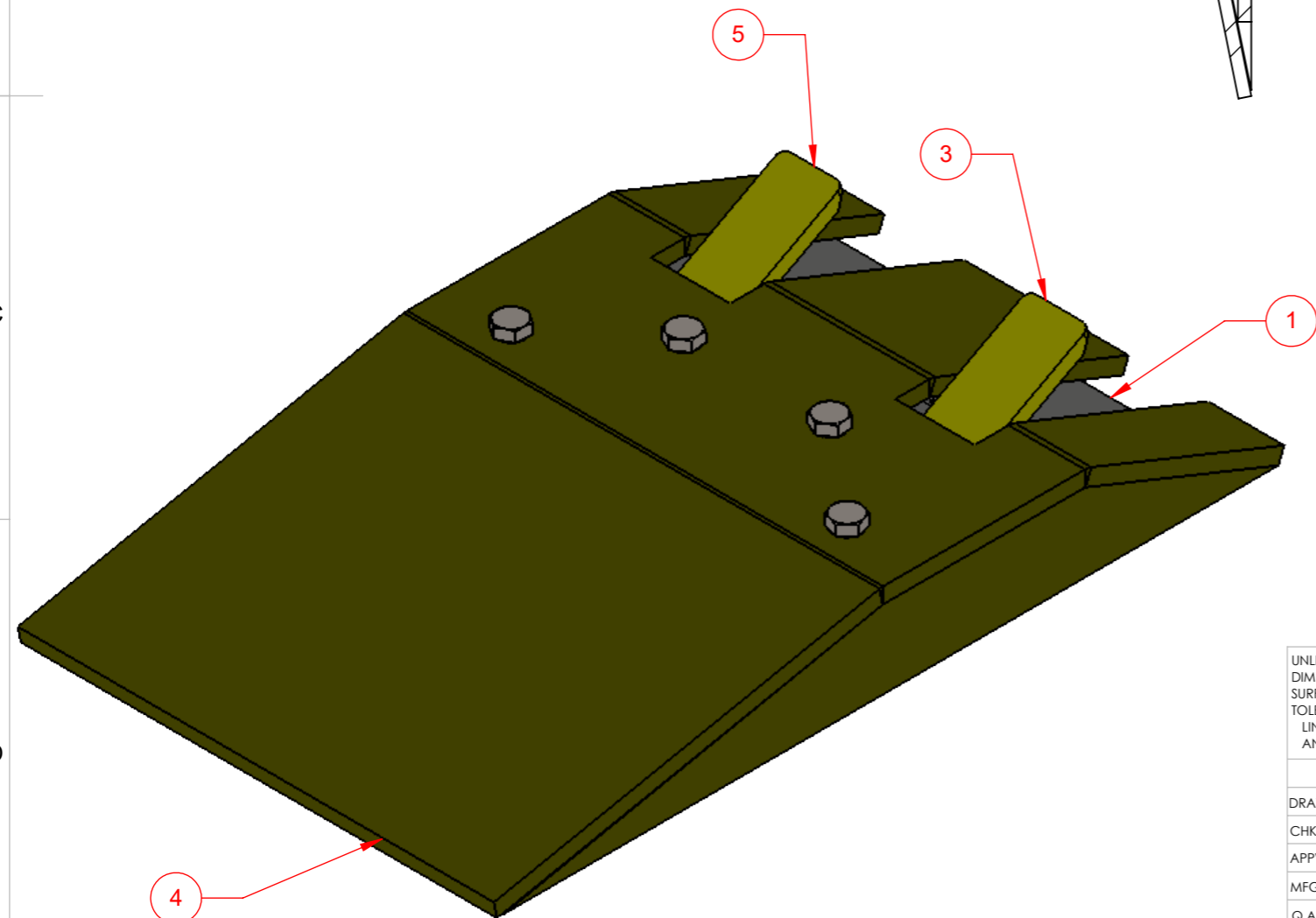

UNLESS OTHERWISE SPECIFIED: DIMENSIONS ARE IN MILLIMETERS SURFACE FINISH: TOLERANCES: LINEAR: ANGULAR:		FINISH: <b>Polyester Powdercoated</b>	DEBUR AND BREAK SHARP EDGES	DO NOT SCALE DRAWING	REVISION
DRAWN	F. GROOM	SIGNATURE	DATE	TITLE:	
CHK'D		<i>F. Groom</i>	2/06/16	<b>HGV Traffic Control Plate</b>	
APPV'D				DWG NO. <b>NMFP 01_01</b>	
MFG				SCALE:1:5	
Q.A				SHEET 1 OF 1	
MATERIAL: <b>Low Carbon Steel</b>			WEIGHT:		

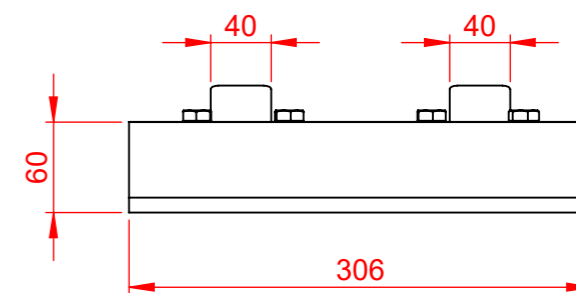
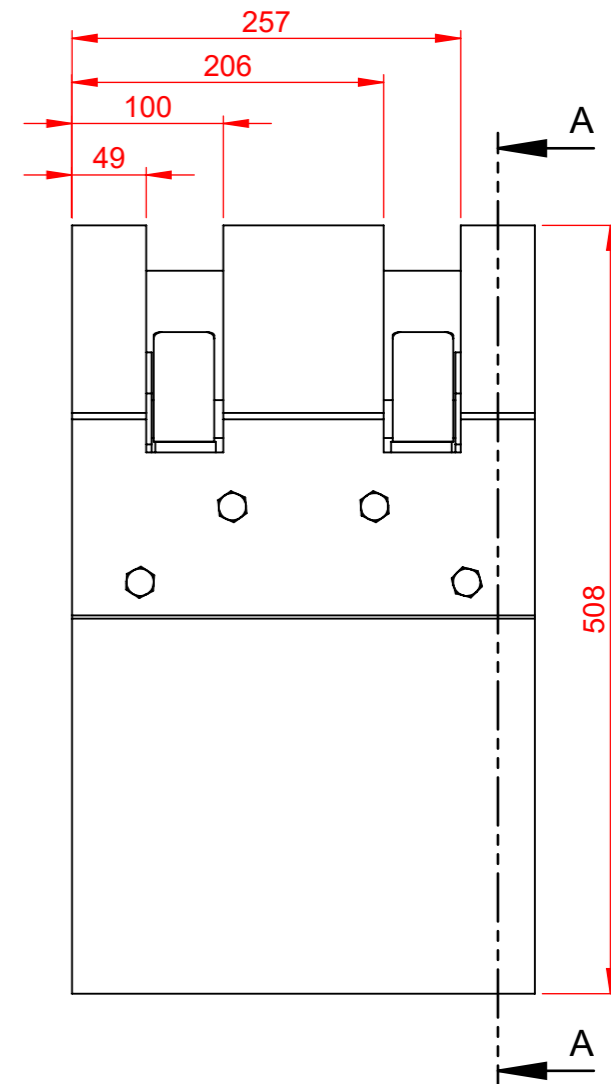
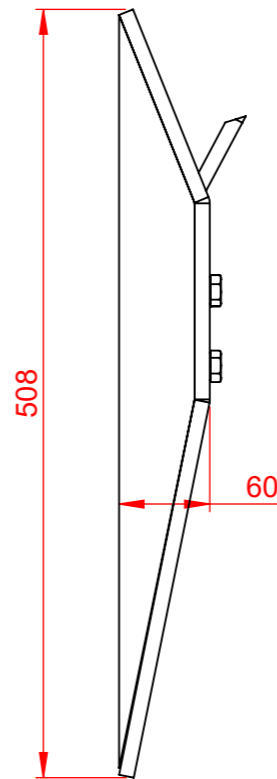
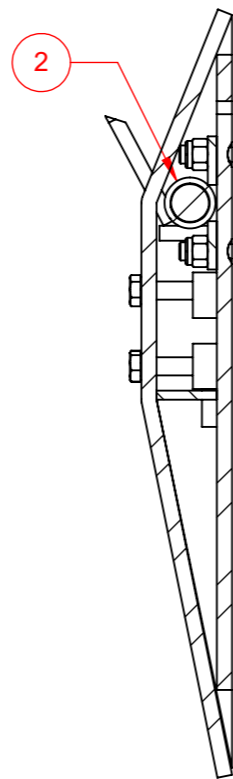
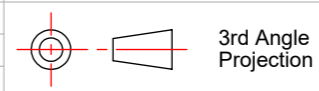

**HGV Traffic Control Plate**  
DWG NO. **NMFP 01\_01**  
A3